

Phæetus[®]

3D Printing System Solution Provider



Supreme Pursuit.



Scan for products details
www.phaetus.com/product

Phaetus Co., Ltd.

E-mail / sales@phaetus.com
Phone / +86 13222205468

About Us

Pursuing excellent products, creating the future of science and technology 3D printing system solution provider



Our Faith:

Reverencing to Hephaestus, the God of fire, stone masonry, sculpture and artisan ancestor in Greek mythology, we gather under PHAETUS, sinking and gaining momentum to fly higher. Outstanding products come from supreme pursuit of details. We inherit the craftsmanship spirit in the field of 3D printing with dedication, lean, concentration and innovation.

Phaetus is committed to the design of extrusion system of filament in-and-between, research and development of the printing filament as well as printing process. At the same time, we provide customers with software and hardware integrated system solutions such as filaments, hotends and printing process based on different applications.

Continuous innovation to solve customers' pain points and providing premium products and solutions for 3D printer users are the direction and goal of our efforts.

Focusing on the medium and high-end market of 3D printing core components, Phaetus adhere to the innovation as the core driving force on the road of development. We have established a strong R & D and marketing team, developed a variety of products to meet the market demand, established sales channels in over 100 countries and regions worldwide, and gains a good popularity and influence in 3D printing enthusiasts and communities.

We will keep working hard and making continuous innovation, to achieve the goal of becoming a leader in the subdivided field of 3D printing!

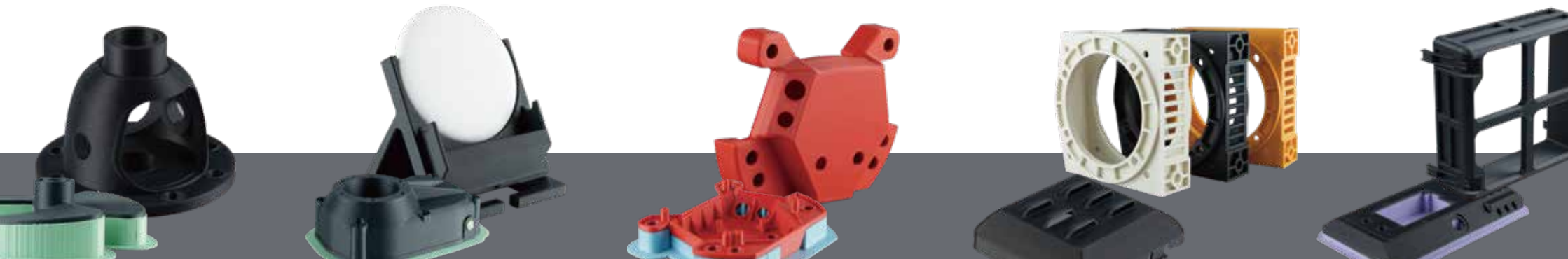

Ultimate Hotends

Fits To Printing Farms / Studios / Enterprises / Factories



Dragon Hotend UHF

Product Features

- Ultra-high flow printing up to 70mm³/s
- 0.25mm thin-walled titanium tube for heat insulation
- One-handed nozzle changing
- 500 °C temperature resistance all-metal kit

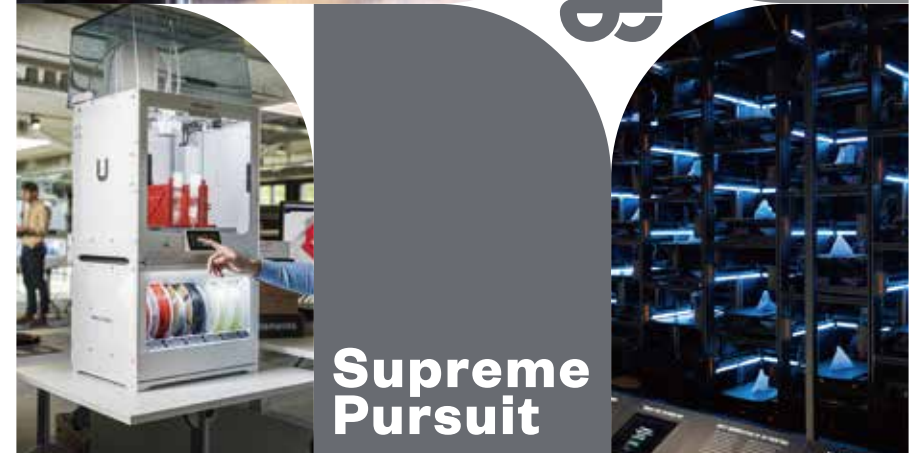

Supreme Pursuit



HF Printing Flow
20~30mm³/s

UHF Printing Flow
>30mm³/s

Rapido Hotend

Product Features

- Super-high flow printing up to 75mm³/s
- High heating efficiency, taking only 51s to 280°C
- 0.2mm thin-walled heat insulation
- One-handed nozzle changing
- 280°C temperature resistance all-metal kit
- HF/UHF versions interchangeable



HF Printing Flow
20~30mm³/s

UHF Printing Flow
>30mm³/s

Rapido Plus Hotend

Product Features

- Super-high flow printing up to 75mm³/s
- High heating efficiency, taking only 51s to 280°C
- 0.2mm thin-walled heat insulation
- One-handed nozzle changing
- 350°C temperature resistance all-metal kite
- HF/UHF versions interchangeable

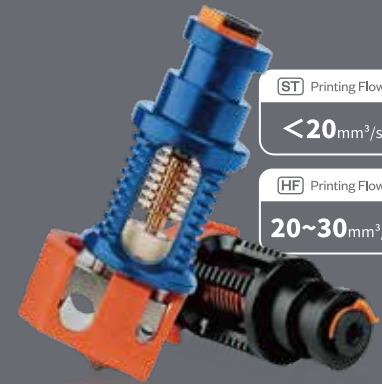

ST Printing Flow
<20mm³/s

HF Printing Flow
20~30mm³/s

Dragon Hotend

Product Features

- 0.1mm thin-walled heat insulation
- Rigid torsion resistant structure
- One-handed nozzle changing
- 500 °C temperature resistance all-metal kit
- ST / HF versions interchangeable



WST Printing Flow
<20mm³/s

WHF Printing Flow
20~30mm³/s

Dragon Water Hotend

Product Features

- 0.1mm thin-walled heat insulation
- Excellent heat dissipation by water-cooling circulation
- Rigid torsion resistant structure
- One-handed nozzle changing
- 500 °C temperature resistance all-metal kit
- ST / HF versions interchangeable



ST Printing Flow
<20mm³/s

TaiChi Hotend

Product Features

- Two-In-One printing and easy leveling
- Tapered bi-metal heatbreak anti-clogging design
- 0.25mm thin-walled titanium tube for heat insulation
- One-handed nozzle changing
- 500 °C temperature resistance all-metal kit

Cost-Effective Hotends

Fits To Makers / Educational Users



Drangonfly Hotend HIC

Product Features

- Integrated welded nozzle
- Lengthened nozzle and heatblock
- Side envelope surface fixed structure
- 0.25mm thin-walled heatbreak
- Suitable for high-temperature and abrasive filaments



Supreme Pursuit



Drangonfly Hotend BMS

Product Features

- Conical fitting of heatbreak and heatsink making a perfect heat dissipation
- Heatbreak inner wall roughness Ra0.3 reducing the risk of clogging
- 500 °C temperature resistance, plated copper core components

Direct Adaptation Models

Crealitty Series



Drangonfly Hotend BMO

Product Features

- Conical fitting of heatbreak and heatsink making a perfect heat dissipation
- Heatbreak inner wall roughness Ra0.3 reducing the risk of clogging
- 500 °C temperature resistance, plated copper core components

Direct Adaptation Models

Prusa / Voron Series

Co-Branding Hotends

Customized Co-branded with 3D printer manufacturers



About Voron

VORON is an open source 3D printer project, which is dedicated to creating production-quality printers you can assemble in your kitchen.

Dragon Hotend Voron edition is our customized product for Voron users seamlessly compatible with Voron 3D printers.

Welcome 3D printer manufacturers to have a co-branding cooperation with Phaetus

You will get Phaetus'

Technical Support

&

Brand Customization



Phaetus × Voron Dragon Hotend

Product Features

- Compact structure, stable performance
- 0.1mm thin-walled heat insulation
- One-handed nozzle changing
- ST / HF versions interchangeable

Phaetus × Voron Dragon Hotend

Product Features

- Compact structure, stable performance
- 0.1mm thin-walled heat insulation
- One-handed nozzle changing
- ST / HF versions interchangeable

High Quality Nozzles

Preferred on any high-end 3D printer

Tungsten Carbide Nozzle

One For All Filaments



9.0 Hardness (Mohs)	550 °C Maximum Printing Temperature	130 W/m.k Thermal Conductivity	4.5 $\mu\text{m}/\text{m}\cdot\text{°C}$ Coefficient of Thermal Expansion
----------------------------------	--------------------------------------------------	---------------------------------------------	----------------------------------------------------------------------------------------

Filament Compatibility

From conventional PLA to high temperature filaments like PEEK and even carbon fiber reinforced filaments. The Tungsten Carbide Nozzle has a very high wear resistance and as such will last a life-time. This is "The one nozzle for all filaments".

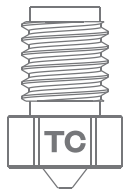

TC Nozzle Wear Resistance Testing

Filament: Carbon Fiber Composite Filament
 Filament weight: 20kg+
 Print temperature: 290°C
 Print speed: 77.0mm/s
 Nozzle Orifice: 0.4mm

Before Printing

Orifice Diameter

0.4033mm



After Printing

Orifice Diameter

0.4641mm

Printed Filament

20878.6g



Min. Orifice Diameter
 $\phi 0.25$



Tolerance
 $\pm 0.01\text{mm}$



Inner Hole Roughness
 $\leq \text{Ra}0.4\mu\text{m}$



Concentricity
 $\leq 0.02\text{mm}$



Supreme Pursuit

Brass Nozzle

3.0	300 °C	105 W/m.k	18.0 $\mu\text{m}/\text{m}\cdot^{\circ}\text{C}$
Hardness (Mohs)	Maximum Printing Temperature	Thermal Conductivity	Coefficient of Thermal Expansion

Filament Compatibility

Wide application with high cost performance, printing well with conventional filament, such as PLA, ABS, TPU, PA, PP, PC, ASA, Nylon, PETG, PVA, HIPS and etc.

Plated Copper Nozzle

6.0	500 °C	330 W/m.k	16.7 $\mu\text{m}/\text{m}\cdot^{\circ}\text{C}$
Hardness (Mohs)	Maximum Printing Temperature	Thermal Conductivity	Coefficient of Thermal Expansion

Filament Compatibility

Working well for high temperature applications, printing with filaments such as PEEK, PEKK, PEI, PSU, PPSU and etc.

DLC Hardened Steel Nozzle

7.8	450 °C	26 W/m.k	12.0 $\mu\text{m}/\text{m}\cdot^{\circ}\text{C}$
Hardness (Mohs)	Maximum Printing Temperature	Thermal Conductivity	Coefficient of Thermal Expansion

Filament Compatibility

Wear-resistance, high temperature performance, suitable for 3D printing composites with abrasive additives such as Carbon Fiber, Steel, Wood, Boron Carbide, Tungsten and Phosphorescent pigment as well as conventional filaments.

Hardened Steel Nozzle

7.8	450 °C	22 W/m.k	8.0 $\mu\text{m}/\text{m}\cdot^{\circ}\text{C}$
Hardness (Mohs)	Maximum Printing Temperature	Thermal Conductivity	Coefficient of Thermal Expansion

Filament Compatibility

Wear-resistance, High temperature performance, suitable for 3D printing composites with abrasive additives such as Carbon Fiber, Steel, Wood, Boron Carbide, Tungsten and Phosphorescent pigment as well as conventional filaments.

Stainless Steel Nozzle

5.0	350 °C	17 W/m.k	6.0 $\mu\text{m}/\text{m}\cdot^{\circ}\text{C}$
Hardness (Mohs)	Maximum Printing Temperature	Thermal Conductivity	Coefficient of Thermal Expansion

Filament Compatibility

Food-level applications, suitable for 3D printing of food, biomedical, and etc.

Filaments

A wide range of high performance engineering filaments
Meet various printing requirements

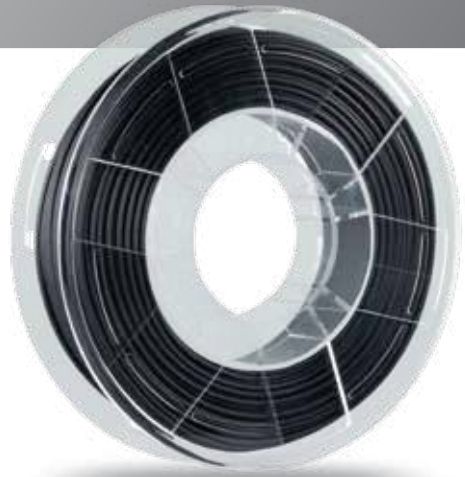

aeCarbon™ UltraPA-CF

High temperature polyamide based with 15% chopped carbon fiber reinforced FDM filament



Smart Fiber
Reinforced Technology



Low Moisture
Sensitivity



Super Abrasive
Resistance



High Heat
Resistance

Print temp	300-320°C
Bed temp	70-80 °C
Net weight	0,5/1kg
Diameter	1,75 mm/2,85mm

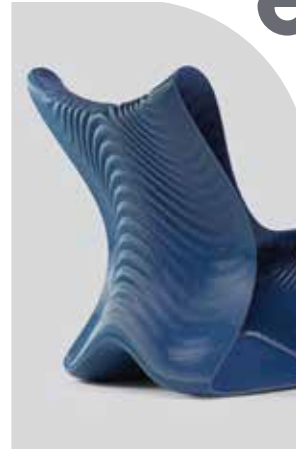

Supreme Pursuit

aeGlass™ UltraPA-GF

High temperature polyamide based with 15% chopped glass fiber reinforced FDM filament

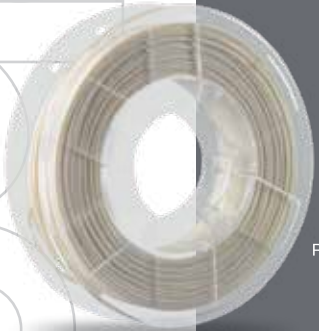

Smart Fiber Reinforced Technology



Low Moisture Sensitivity



Super Abrasive Resistance



Color Diversification

Print temp	280-320°C
Bed temp	70-80 °C
Net weight	0.5/1kg
Diameter	1.75 mm/2.85mm

aeSupport™ S-Green

Quick-Remove Support Filament

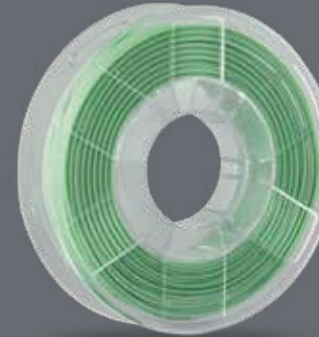

Smart Adhesion Technology



Quick Remove Technology



ECO Friendly

Print temp	280-290°C
Bed temp	60-80 °C
Net weight	1kg
Diameter	1.75 mm/2.85mm

aeCarbon™ EasePA-CF

Long-chain polyamide12 based with 15% chopped carbon fiber reinforced FDM filament

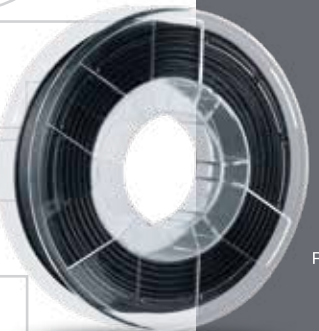

Smart Fiber Reinforced Technology



Low Moisture Sensitivity



Super Abrasive Resistance



High Heat Resistance

Print temp	280-300°C
Bed temp	40-70 °C
Net weight	0.5/1kg
Diameter	1.75 mm/2.85mm

aeSupport™ S-Purple

Quick-Remove Support Filament

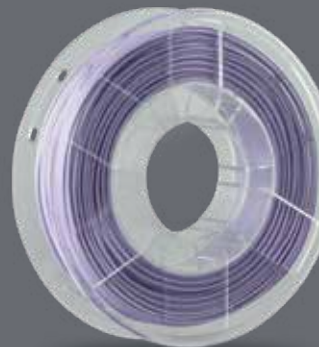

Smart Adhesion Technology



Quick Remove Technology



ECO Friendly

Print temp	280-290°C
Bed temp	60-80 °C
Net weight	1kg
Diameter	1.75 mm/2.85mm

Thermal Conductivity W/m.k

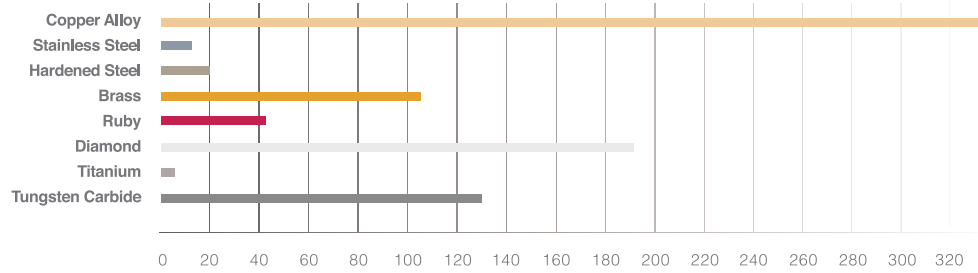

Hardness (Mohs)

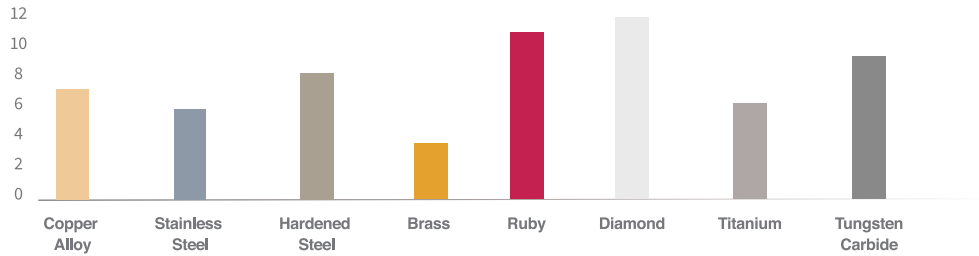

Coefficient of Thermal Expansion $\mu\text{m}/\text{m}\cdot\text{C}$

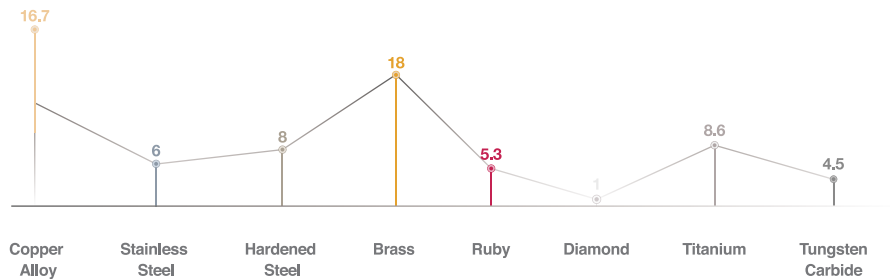

Suitable Filaments for Nozzles & Hotends

No.	Category	Name	Suitable Nozzle	Recommended Hotend	Flow Rate
1	Consumer Grade Filament	Tough-PETG	Brass Nozzle	Dragon series Dragonfly series	ST:<20mm ³ /s HF:20~30mm ³ /s
2		Low Odor ABS			
3	Flexible Filament	aeFlex 95A	Plated Copper Nozzle	OmniaDrop V3	UHF:>30mm ³ /s
4		aeFlex 90A			
5		aeFlex 85A			
6		aeFoam			
7	Pure Nylon Filament	ToughPA	Hardened Steel Nozzle/ Tungsten Carbide Nozzle	Dragon series Dragonfly series	ST:<20mm ³ /s HF:20~30mm ³ /s
8		UltraPA			
9	Glass Fiber Reinforced Filament	aeEase PA-GF	Hardened Steel Nozzle/ Tungsten Carbide Nozzle	Dragon HF/Dragonfly HIC	HF:20~30mm ³ /s
10		aeUltra PA-GF			
11	Carbon Fiber Reinforced Filament	aeEase PA-CF	DLC Hardened Steel Nozzle/ Tungsten Carbide Nozzle	Dragon HF/Dragonfly HIC	HF:20~30mm ³ /s
12		aeUltra PA-CF			
13		aeEase PA-CF			
14	Support Filament	aeS-Green	Hardened Steel Nozzle/ Tungsten Carbide Nozzle	Dragon series Dragonfly series	ST:<20mm ³ /s HF:20~30mm ³ /s
15		aeS-Purple			
16		S-PVA water-solubilitysustain			

Extruders

Light, Smart, Efficient

Super Extrusion Force

6.3 : 1 Gear Ratio



APUS Extruder

Born To Run

Product Features

- Super extrusion force
- Light weight all metal design
- Universal mounting system
- Easy maintenance



Specialized teeth design of **the dual drive gear system** to get a very good grip on filament with very high reliability

Light Weight All-Metal Design

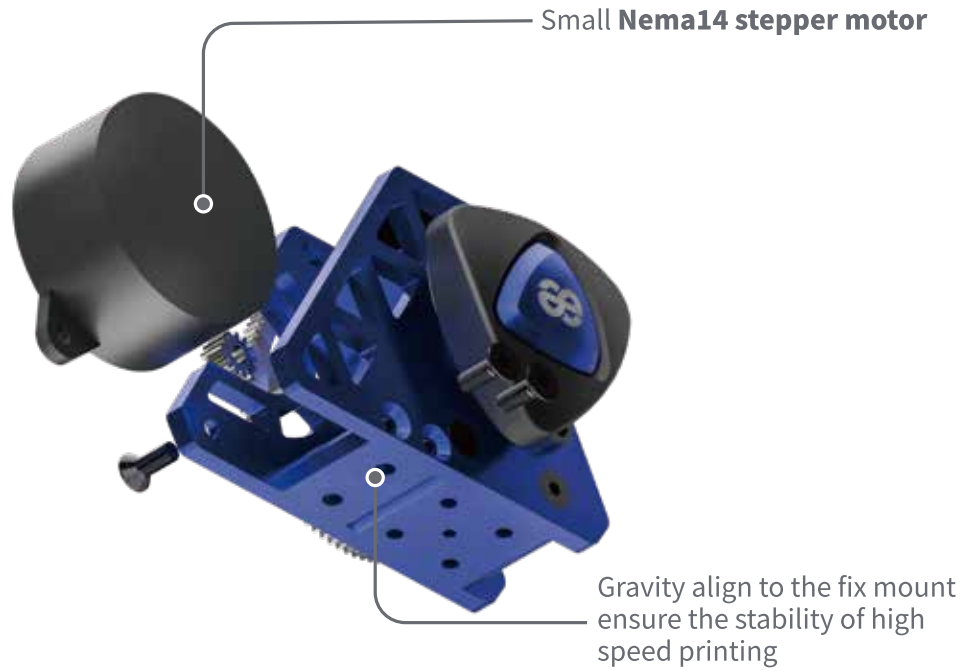

Universal Mounting System

Compatible with all kinds of hotends because of easy switching hotend system



Easy Maintenance

